

# KFDJ & KFDS-FS Diverters

## Managing fluid below the rotary

### 500/1000/2000 psi Diverter Systems

The industry standard for offshore drilling & production for over 50 years

#### Product description

- HMH diverter systems lead the offshore drilling market, providing field-proven protection from shallow gas blowouts while minimizing equipment handling time and enabling longer up-time. In the event of a shallow gas kick, the diverter is energized to seal around the drill pipe and divert the gas safely overboard
- A diverter system is often used during top-hole drilling and is primarily used for the potentially hazardous flows that can be experienced prior to setting the casing string on which the BOP stack and choke manifold will be installed
- The diverter system is not intended to shut-in or halt well flow, rather it provides a low-pressure flow control system to direct controlled or uncontrolled wellbore fluids away from the immediate drilling area for the safety of personnel and equipment
- The HMH KFDJ and KFDS-FS diverter systems are used on a variety of land and offshore rig types to protect against shallow gas kicks during drilling operations
- HMH KFDJ diverters include a full range of insert packer sizes, all of which use a “J” type running tool
- The HMH KFDS-FS diverter system utilizes a conventional annular-style packing element
- HMH is a single-source supplier for complete diverter solutions, including diverter assembly, controls, valves, spools, and overshot packers. An integrated package, engineered to specific requirements will provide maximum safety, efficiency and savings



# Diverter Housing

HMH diverters meet or exceed  
API RP64 or API Standard 64

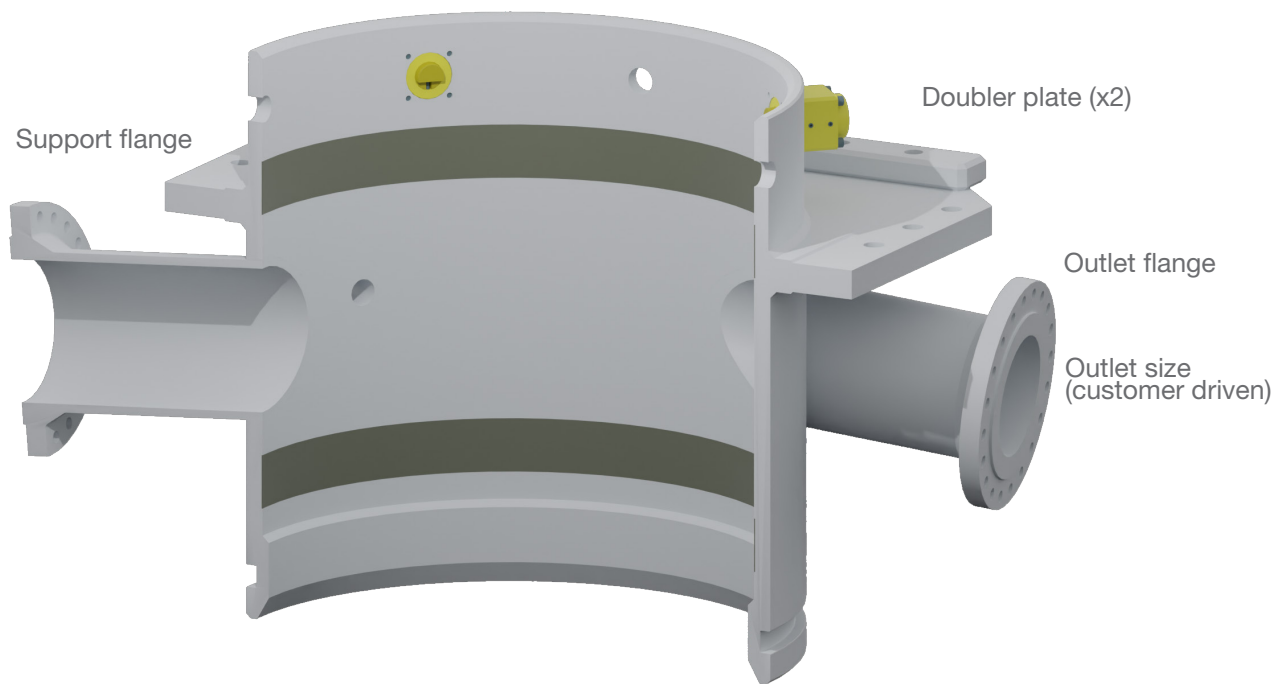

## Product description

The standard diverter support housing comes with a main flow return line and two vent lines up to 20" diameter and can be configured for any of our diverter inserts. Additional outlets can be added as required. The support housing is installed by bolting against a pair of doubler plate which is pre-welded onto the rotary beams. Standard ball valves come with electrical feedback sensors for remote monitoring of the valve open/close position.

Diverter Overview	
Application	Platform/jackup/Floater Installed above BOP
Rotary Table Options (in.)	37-1/2, 49-1/2, 60-1/2, 75-1/2
Diverter to body Latch	KFDS-FS and KFDJ -Hydraulic latch or KFDJ "J" - J-latch
Closing Range (inches)	5.0 - 36.0 OD
Outlet Sizes	4" to 20"
Pressure Ratings (psi)	500, 1000, & 2000
Operating Pressure (psi)	1,500 - KFDJ 500 & KFDJ 1000 2,200 - KFDJ 2000
Main Components	Diverter Body Packer & Insert Packer Flowline Seals J-Ring Overshot Spool

# KFDS-FS

The KFDS-FS diverter is a single packing element workhorse

## Product description

The KFDS-FS version utilizes an annular-style packing element which eliminates the need for variable size packers to seal on different size pipes.

The HMH KFDS-FS has a long successful history on rigs with 49-1/2, 60-1/2 and 75-1/2 rotary tables.

## Benefits

- Uses Hydril Pressure Control MSP components delivering long, dependable service life, as proven by the MSP's consistent field performance over the past 50 years
- Field-replaceable wear plate that eliminates contact between the packing unit inserts and the diverter head, making repair fast and economical
- Bolted-in inner sleeve that eliminates the need to stress relieve if the inner sleeve is damaged in the field
- Conical bowl design of the piston provides a simple and efficient method of closing the packing unit
- Seals on drill pipe, kelly, tool joints, tubing, wireline, and will completely seal off an open hole (CSO) to full rated pressure
- Can be configured with top or bottom hydraulic connections to suit customer requirements
- Capable of complete well bore shutoff (CSO) with legacy active flowline seal configuration

## Features

- Qualified to API STD 64, packing element qualified to API 16A 4th edition
- Upper flowline seal swap is simplified
- Back-to-front feedable rubber on the packing unit permitting confident closure of the diverter

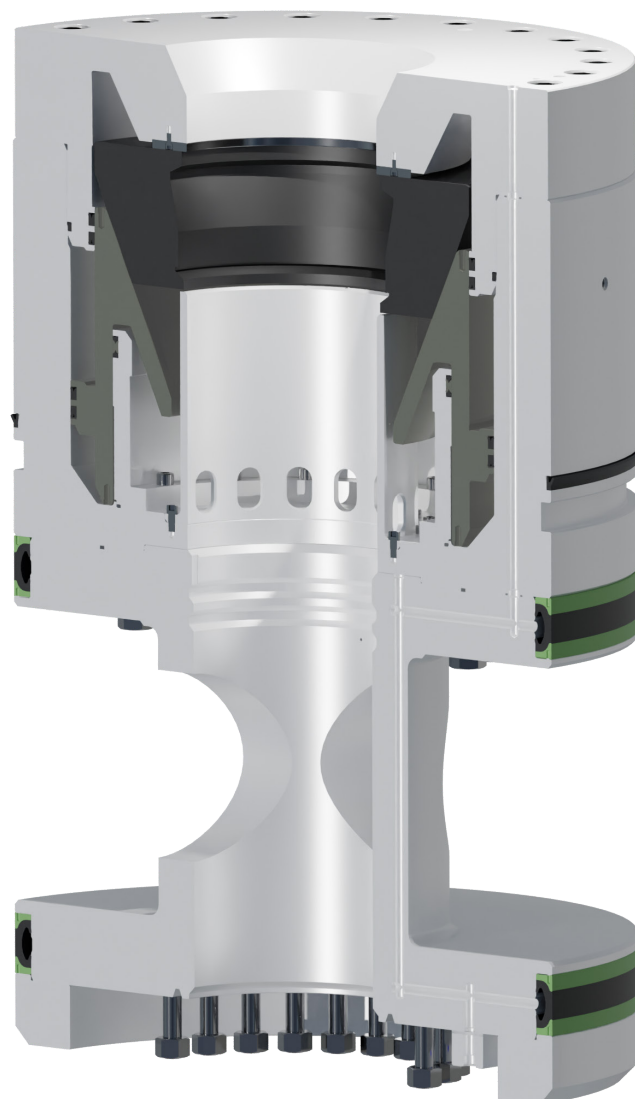

## KFDJ-FS Specifications

Rotary table options (in.)	49-1/2, 60-1/2, 75-1/2
Bore (in.)	21.25
Working pressure (psi)	500 or 2000
Closing range (in.)	CSO to 21" OD
Volume to close (gal)	31.1
Volume to open (gal)	18.9
Packer operating pressure (psi)	1300
Flowline seal operating pressure (psi)	350
Hangoff capacity (kip)	2,500
Upthrust capacity (kip)	2,000
Regulatory Conformance	API Standard 64

# KFDJ Big Bore Diverter

The big bore KFDJ diverter assembly (36-1/2" bore diameter) will sit within the 49-1/2" rotary support housing. It works with a combination of insert packers with the help of handling tool, running tool and J-rings to provide sealing options for sizes of drill pipes stated in technical specifications below.

The Diverter assembly, overshot spools and overshot packers can be pulled or run without connecting or disconnecting the flow return line, vent lines and other auxiliary lines linked to the diverter.

Big bore diverter (36-1/2" bore diameter) and its overshot equipment are supplied with nominal 39" EC-6 connectors. Overshot equipment consists of pipes with minimum 0.75" wall thickness. Typical package consist of 39" overshot spools, 36" overshot packer, 30" overshot packer, 24" overshot packer and overshot mandrel with flange to suit the BOP annular top connection. These overshot packers reduce the nipple up time normally required to weld flanges or hubs to casing.

## Diverter handling tool

- Standard handling tool is 4 1/2 in. IF API tool joint box up and pin down and can accommodate other tool joints as required. The optional test tool provides the means to pressure test the entire diverter system.

## Sealing elements

- A broad range of sizes to meet your drilling program needs
- Qualified to API STD 64

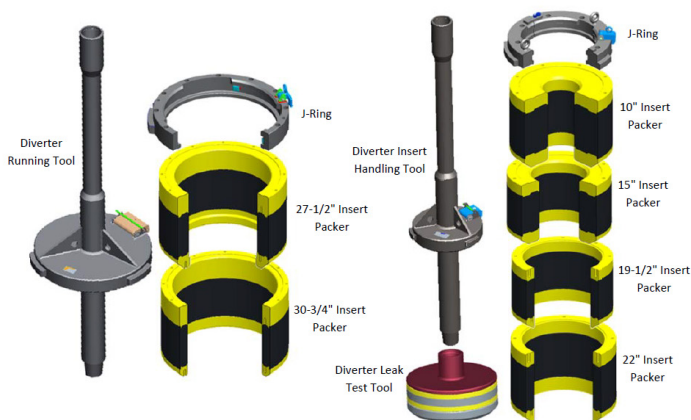

R23011-7 49.5 Rotary Big Bore Diverter Assembly

# KFDJ Standard Bore Diverter

The standard bore KFDJ assembly (27-1/2" bore diameter) will sit within the 49-1/2" rotary support housing. It works with a combination of insert packers with the help of handling tool, running tool and J-rings to provide sealing options for sizes of drill pipes stated in technical specifications.

The Diverter assembly, spacer spools and overshot packers can be pulled or run without connecting or disconnecting the flow return line, vent lines and other auxiliary lines linked to the diverter.

Standard bore diverter (27-1/2" bore diameter) and its overshot equipment are supplied with nominal 32" EC-6 connectors. Overshot equipment consists of pipe with minimum 0.75" wall thickness. Typical package consist of overshot spools, 30" overshot packer, 24" overshot packer and overshot mandrel with flange to suit the BOP annular top connection. These overshot packers reduce the nipple up time normally required to weld flanges or hubs to casing.

## Diverter handling tool

- Standard handling tool is 4 1/2 in. IF API tool joint box up and pin down and can accommodate other tool joints as required. The optional test tool provides the means to pressure test the entire diverter system.

## Sealing elements

- A broad range of sizes to meet your drilling program needs
- Qualified to API STD 64

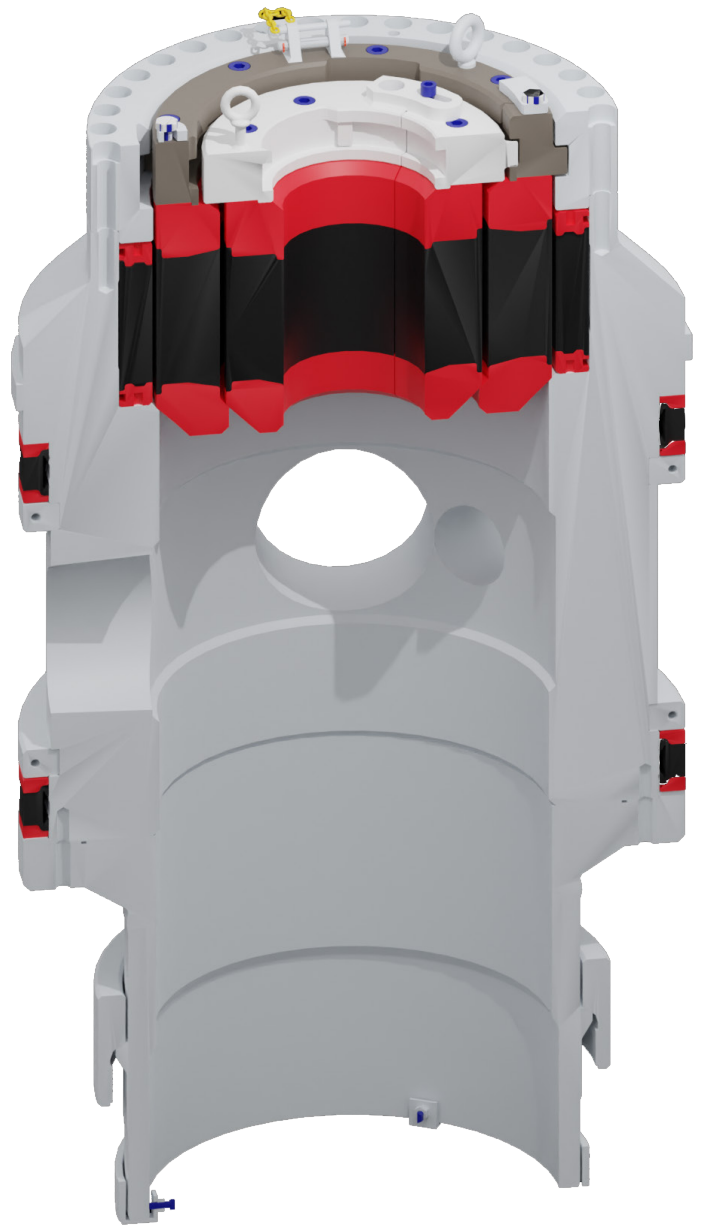

R23010-49.5 Rotary Standard Diverter Assembly

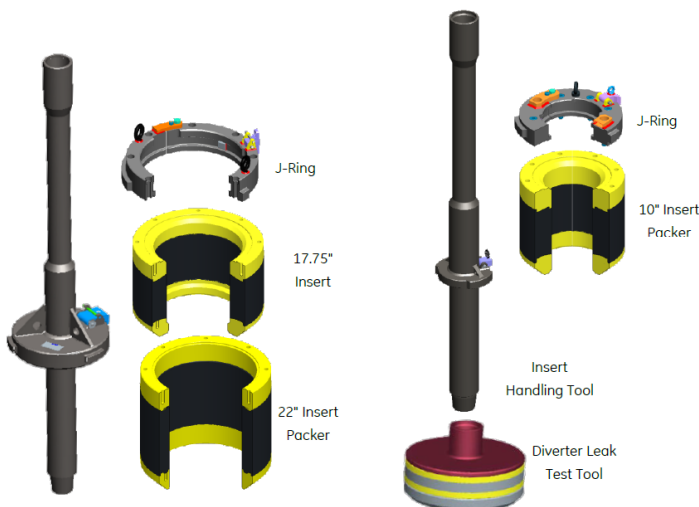

## Key features

The KFDJ diverter was developed for platforms and jackup rigs, is rated for 500, 1000 or 2000 psi wellbore pressure and designed to run through the rotary to maximize operating time. The KFDJ systems are in wide use globally and supported by HMH through our regional service facilities.

- The fixed support housing is a proprietary feature securely bolted to the rotary beams and provides fixed outlets for flowline, fill-up line, and vent lines
- The support housing allows installation of outlets up to 20 in. diameter to virtually any configuration
- The diverter system is qualified to API STD 64
- The diverter, spacer spool, and overshot packer assembly may be retrieved or run without connecting or disconnecting the flowline, fill-up line, and vent lines
- Single or dual overshot packer assemblies are available and equipped with hydraulically inflatable seals which allow them to be stabbed over the conductor pipe and corresponding mandrels mounted on top of BOP stacks. This eliminates the need for welding and/or making up flanges each time different size casing is run
- Overshot packer assemblies are also equipped with wash out ports to clean out debris in the area above the seal(s) and in the annular area between the OD of the conductor /mandrel and ID of the overshot packer housing
- Overshot spools and packers feature the reliable EC-6 coupling for fast, sure make-up
- Mudline suspension hangers and bit sizes up to 27.41 in. for 37 1/2 in. rotary tables or 36.41 in. for 49 1/2" rotary tables can be run without removing the diverter assembly
- The diverter, spacer spool, and overshot packer each fit through a 37 1/2 in. rotary table. Minimum bore through the standard support housing is 36 1/2 in. ID for the 37 1/2 in. rotary installation

- A BIG BORE option is available for the 49.5 in rotary system to attain the full 37.5 in. bore. The overshot packer on the bottom of the diverter spacer spool assembly reduces rig-up time by eliminating welding of flanges or hubs to casing
- Complete protection while running casing strings and open borehole is provided by a full range of insert packer sizes, which all use a "J" type running tool
- Available with rotating insert to provide low back pressure packoff on the kelly or drill pipe during drilling

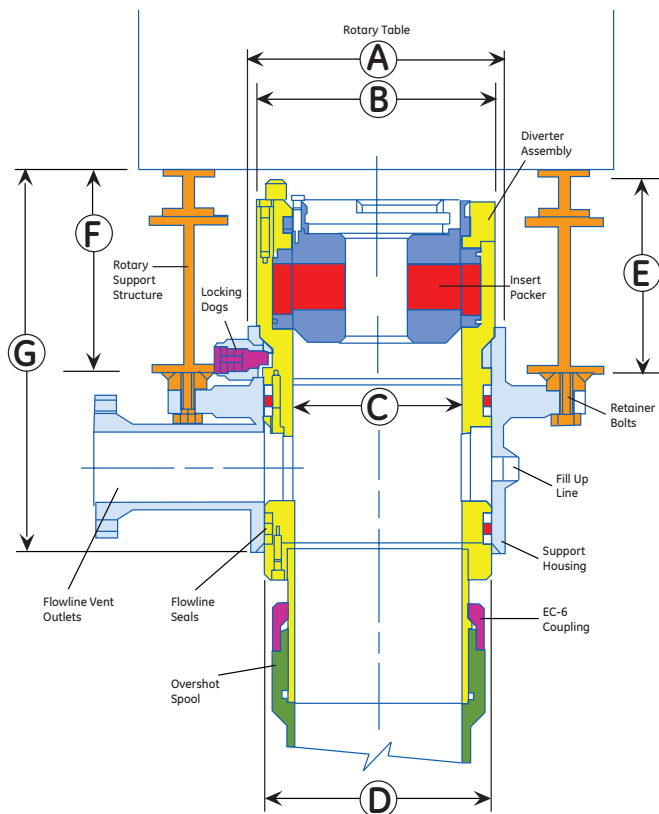

**KFDJ Dimensional Data - Standard hookup KFDJ with 12 in. nominal outlets**

Rotary Table (in.)	A	B	C	D	E	F	G
37.50 in. Standard	42.50	37.25	27.50	36.50	31.37	32.37	60.75
49.50 in. Standard	53.00	49.25	36.50	47.00	38.00	39.00	67.37

# KFDJ-"J"

## Key features

Designed with all the field-proven features of the standard KFDJ diverter, yet with fewer hydraulic connections, the HMH KFDJ "J" diverter system includes a "J-lock" between the diverter and support housing.

- The KFDJ "J" requires just 3 hydraulic functions for energizing/venting the following seals
- Diverter packer; energize/vent
- Flowline seals; energize/vent
- Overshot packer; energize/vent

The "J-lock" slots in the support housing align the diverter and housing outlets. A mechanical latch secures the diverter in the housing and the handle position provides a clear visual indication of lock engagement. Other features include:

- Simplified design
- All components of the support housing and the diverter assembly are heavy wall construction for pressure containment and erosion protection during high velocity, multi-phase flow
- Full size range of packer inserts

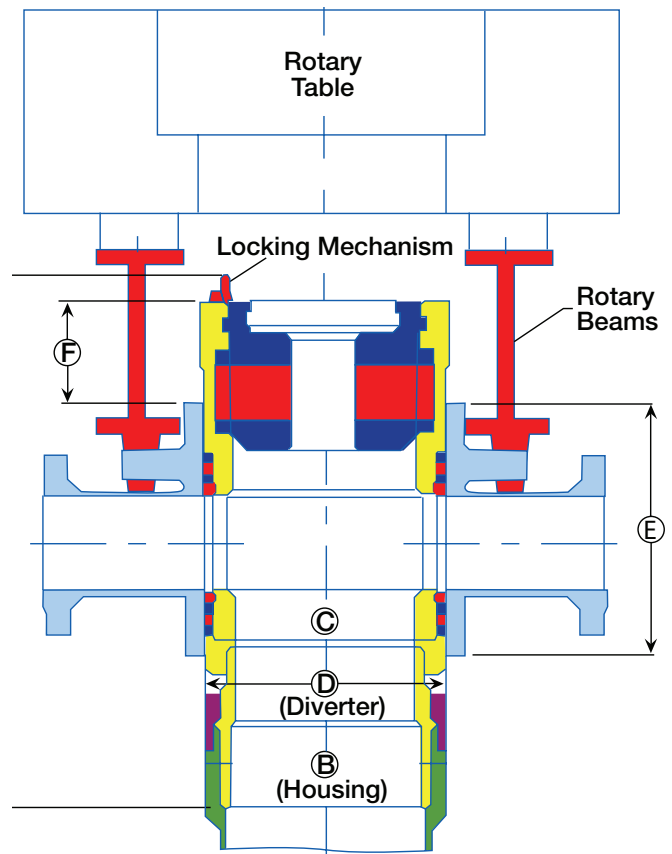

KFDJ "J" Dimensional Data - Standard hookup KFDJ "J" with 12 in. nominal outlets						
Rotary Table (in.)	A	B	C	D	E	F
37.50 in.	78.50	36.50	27.50	36.25	35.25	15.62
49.50 in.	73.25	47.00	27.50	46.75	35.25	10.40

KFDJ Equipment	
Item/Parameter	Standard and Big Bore KFDJ Feature/Information
KFDJ-500 or KFDJ-1000 Diverter Support Housing suitable for use with 49-1/2" rotary table	<p>Diverter system designed to the intent of API RP64</p> <p>Flanges designed to the intent of ASME B16.5</p> <p>Pipes designed to the intent of ASME B31.3</p> <p>Metallic components to NACE MR 0175</p> <p>Outlet pipe: SCH 80 (Default offer)</p> <p>Outlet flange ring groove cladding:</p> <p>Option A: SS 316 (Default offer)</p> <p>Option B: Inconel 625 (Premium offer)</p> <p>Flowline seal area on the support housing</p> <p>Option A: No extra cladding (Default offer)</p> <p>Option B: Inconel 625 (Premium offer)</p>
ASME flange end ball valve with hydraulic actuator, installed with position indicator.	<p>Flanges on ball valve:</p> <p>Option A: SS 316 (Default offer)</p> <p>Option B: Inconel 625 (Premium offer)</p> <p>Position Indicator (Feedback signal for remote monitoring)</p> <p>Option A: Electrical switch box</p> <p>Option B: Pneumatic switch box</p> <p>*No external cable glands or cable provided.</p>
KFDJ-500 or KFDJ-1000 Diverter Assembly	Standard bore (27-1/2" bore diameter)
Pressure Ratings	<p>KFDJ-500: 500 psi</p> <p>KFDJ-1000: 1000 psi</p>
Hang off capacity	100 kips
Minimum Steel design temperature	20°C (-4°F)
Hydraulic operating pressure	750 psi (lock in pressure) up to 20% above bore pressure.
Flowline seals hydraulic operating pressure	250 psi – 1500 psi
36" (BB only) 30" and 24" overshot packer hydraulic operating pressure	<p>KFDJ-500: *250 psi (lock in pressure)</p> <p>KFDJ-1000: *500 psi (lock in pressure)</p>
Locking dog hydraulic operating pressure	1500 psi (lock in pressure)
Doubler plate	A516 GR70-S5 or equivalent material
Tubing assembly for Locking dog	Stainless steel material (SS316)
Elastomer material for packers and flowline seals	<p>Nitrile (NBR) material is recommended for use with sweet gas and/or crude, low aromatic fluid (&lt;20% aromatic), water and ethylene glycol base fluids (Hydrolubes).</p> <p>Recommended Operating Temperature Range :</p> <p>40°F to 180°F (4°C to 82°C)</p> <p>NBR packers are not suitable for H2S service.</p>
NACE Compliance	<p>Applicable to metal component that will be in constant contact with wellbore fluid during drilling operations.</p> <p>i.e. Diverter main body, Support housing pipe outlets, Overshot equipment end connectors</p>



KFDJ Packer Insert Closing Ranges and Volumes										
	Packer I.D. (in)	Diverter I.D. (in)		Casing/Pipe Dia (in)	Max Bore Pressure (psi)			Closing Volume (Gal.)	Part Number	
		27.5	36.5		KFDJ-500	KFDJ-1000	KFDJ-2000			
Insert Packer	10.00	✓	✓	5.00	500	1000	2000	2.7	H11226-1	
				8.00				1.3		
	15.00	✓	✓	8.00		500	500	5.9	A20955-1	
				10.75				4.0		
				13.375				1.7		
	17.75 (MMS)	✓	N/A	8.00		500	500	9.2	722998	
				10.75				7.3		
				13.375				5.0		
				16.00				2.1		
	19.5	N/A	✓	16.00		500	500	4.6	H11925-1DW1	
	22.00	✓	✓	16.00				8.3		
				18.625				5.0		
				20.00				3.1		
27.5	N/A	✓	24.00	500	500	6.6	-			
30.5	N/A	✓	26.00			9.3				
30.75	✓	✓	26.00			9.9				
30.75	✓	✓	30.00			1.7				
Outer/ Liner Packer	28.50	N/A	✓	22.00	500	500	12.0	H176822-1		
				24.00			8.7			
				26.00			5.0			
38.00			32.00	500	500	15.4	H139278-13			
Overshot Packer	17.00	N/A	N/A			14.00	500	500	3.4	02117001
	21.00					18.75			3.3	02373901
	24.50			20.00	7.3	02206101				
	26.50			24.00	4.6	04354601				
	30.50			28.00	5.4	H139278-1				
	37.00			36.00	2.7	05748701				

\* to collapse pressure of casing, not to exceed diverter rating.

- N/A - Not available for this diverter size
- Rigs with 49/12" rotary using the big bore (36.5") diverter will require a liner packer to bridge the gap between the 36-1/2" main packer and other insert packers.
- MMS required an insert packer to allow passage of the 17-1/2" BHA. To accomplish this, the 10" insert packer fits inside the 17-3/4" insert. This allows the 17-3/4" insert to pass the 17-1/2" BHA while providing protection on the drill collars followed by the installation of the 10" insert packer to provide protection on the drill pipe.

KFDJ Operating Pressures (psi)				
Component	KFDJ-500		KFDJ-2000	
	Normal	Max	Normal	Max
Diverter Packer	750	1500	750	2200
Flowline Seals	250-300	750	250-300	2000
30" Overshot	300	750	-	-
24" Overshot	300	750	300	2000

