

Hydril Pressure Control H-4™

Subsea Wellhead & LMRP Connectors

The industry standard for offshore drilling and production since 1964

Applications and benefits

Since 1964, the H-4 connector family has been engineered to provide the most reliable, field-proven connector available. These connectors have simple operating characteristics, excellent bending, pressure, and tensile load capacities, hydraulically operated, metal-to-metal wellbore sealing and a long economical service life.

- BOP stack to wellhead connection
- LMRP to BOP stack connection
- Completion tree to wellhead
- Capping stack connection

Key features

H-4 design ensures reliable, quick lock and release

- The hydraulic pistons provide a releasing force 25% greater than the locking force for the same operating pressure supplied on all cylinders. The connector is equipped with separate hydraulic circuits for primary and secondary unlock functions for even greater redundancy
- The H-4 locking dog segments positively retract from the wellhead profile after release, ensuring release of the connector. Springs between the locking dog segments keep the dogs retracted with unlock pressure
- Hydraulic operating system
- Pistons and liners are constructed of corrosion resistant materials to extend field maintenance intervals. Seals have enhanced materials and have been qualified for extended service life
- Primary wellbore VX-style gasket does not require personnel to access area under connector/BOP
- Wellbore gasket is ROV replaceable and retrievable
- Visual indicator rod provides positive, visual indication of locked and unlocked position
- An assortment of gaskets are available to provide a pressure-tight self-energizing seal that can withstand facial separation under external

loads. Connectors have backup wellbore seal profiles for sealing for additional redundancy

- Positive mechanical release – Dog profile design assures retraction of locking dog segments during release

The HMH H-4 Wellhead Connector Advantage

Today's offshore drilling environment is progressing into water depths in excess of 10,000 feet. The DWHD H-4 and SHD H-4 connectors are specifically designed for use in deepwater and other critical service applications where high bending loads are anticipated. Only HMH H-4 connectors can provide such high performance with industry leading safety and reliability.

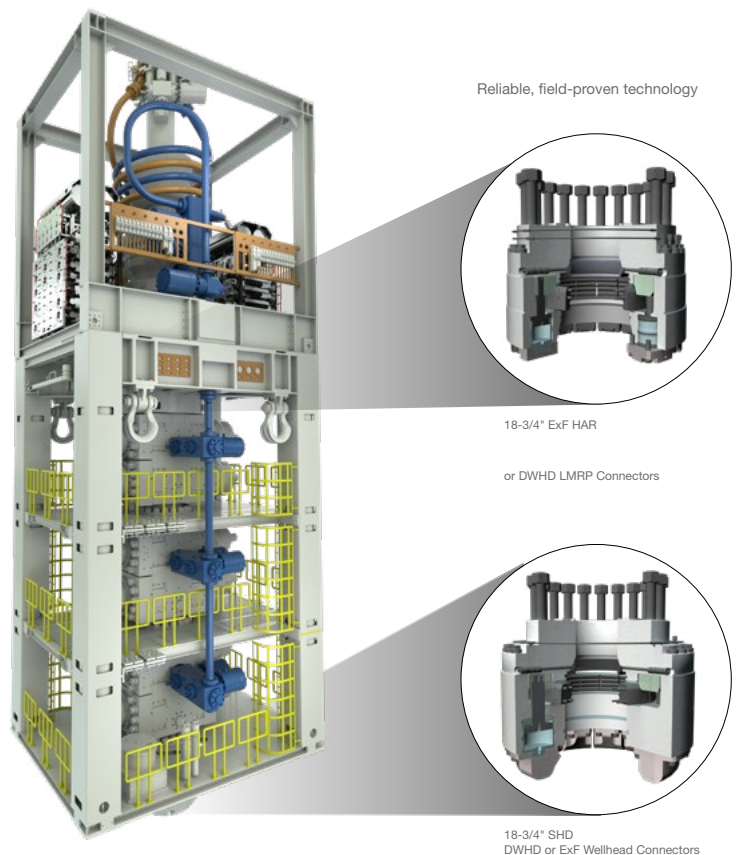

Unequaled performance

The H-4 connector product line has outstanding fatigue capacities. Combining the HMH DWHD H-4 connector and the Baker Hughes DWHC MS-700 wellhead provides a robust interface resulting in significantly increased fatigue life compared to a conventional connector.

This is achieved through the unique load transfer and distribution between the H-4 locking grooves and the additional engagement between the proprietary preloaded

support area on the high pressure housing neck. This load distribution reduces stress concentrations on the wellhead which significantly increases fatigue life.

HMH can also offer the full suite of SFX fatigue enhanced products to increase the overall fatigue life of the wellhead system even more if required. The SFX enhancement leverages use of optimized geometry, material selection and weld grade to achieve the longest fatigue life possible of the connector and wellhead system.

Other advantages

- Reduced stack height
- Internally ported hydraulics
- Gaskets qualified up to 400F and 20Ksi
- Hydraulically actuated gasket retainers
- Glycol flush ports for hydrate mitigation
- Primary and secondary sealing profile (VX/VT)
- 30" to 27" wellhead adapter available on SHD models
- Optional upper body configurations available (flanged, studded, hub)
- Alloy 625 inlaid seal areas (optional - full Alloy 625 wellbore wetted areas)
- Optional gasket nudge pins
- Replaceable wear components
- Wellhead gasket tested to high negative pressure
- Low function volume requirements
- Fully compatible with H-4 and H-4FX profiles

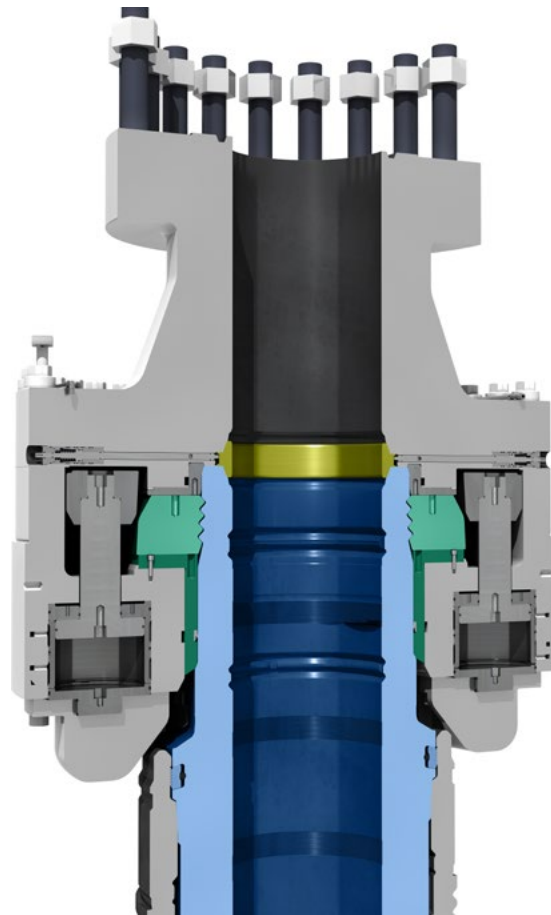

18-3/4" 15k SHD H-4 connector with 27" dog ring kit on a DWHC MS-700 wellhead

18-3/4" 20ksi SHD 30" H-4 connector

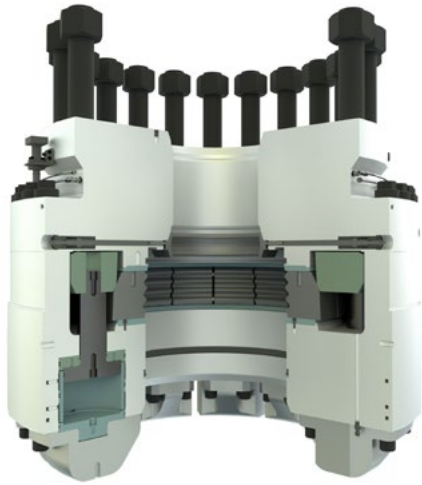

18-3/4" 20ksi SHD H-4 load capacity envelope

Elastic-plastic load capacity per ASME BPVC Section VIII Division 2

Note: Tension values at the wellhead for 3,000 psi connector locking pressure

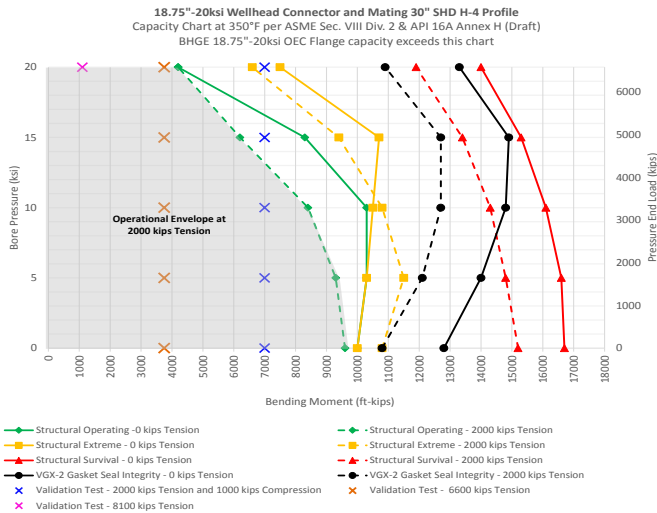

18-3/4" 15ksi SHD H-4 connector

18-3/4" SHD H-4 connector shown with 30" kit

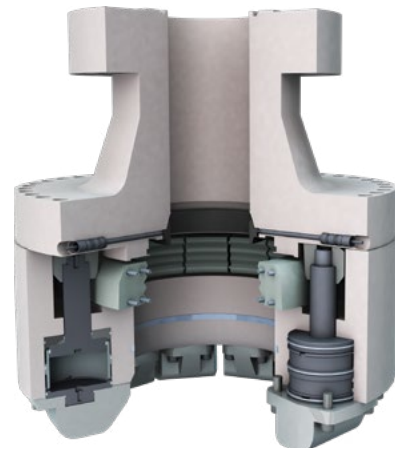

18-3/4" 15ksi SHD H-4 load capacity envelope with 30" kit

Operational load capacity at 2/3 yield strength, extreme load capacity at 0.8 yield strength, survival load capacity at yield strength per API 16A

Note: Tension values at the wellhead for 3,000 psi connector locking pressure

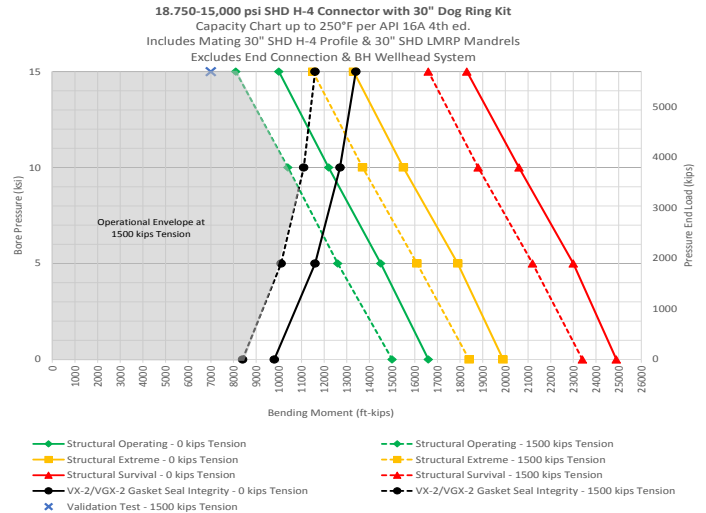

18-3/4" 20K SHD H-4 Technical Specifications

Based on connection with SMS-800	Measurement
Hydraulic circuits	10
Lock fluid volume (US gal)	12.10
Unlock fluid volume (US gal)	15.10
Outside diameter (inches)	66
Weight (lbs)	32,328
Swallow (inches)	32.25
Max. service pressure (psi)	20,000
Max. hydraulic oper. pressure (psi)	3,000
API 16A conformance status	4th Edition PR2

18-3/4" 15K SHD H-4 Technical Specifications

Based on connection with SMS-800	Measurement
Hydraulic circuits	10
Lock fluid volume (US gal)	12.10
Unlock fluid volume (US gal)	15.10
Outside diameter (inches)	66
Weight (lbs)	28,600
Swallow (inches)	32.25
Max. service pressure (psi)	15,000
Max. hydraulic oper. pressure (psi)	3,000
API 16A conformance status	4th Edition PR1

18-3/4" 15ksi DWHD H-4 connector

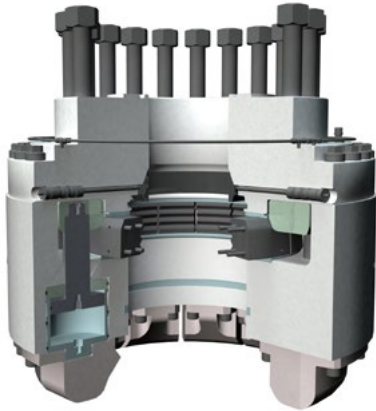

18-3/4" 15ksi DWHD H-4 load capacity envelope

Operational load capacity at 2/3 yield strength, extreme load capacity at 0.8 yield strength, survival load capacity at yield strength per API 16A

Note: Widow values at the wellhead for 3,000 psi connector locking pressure

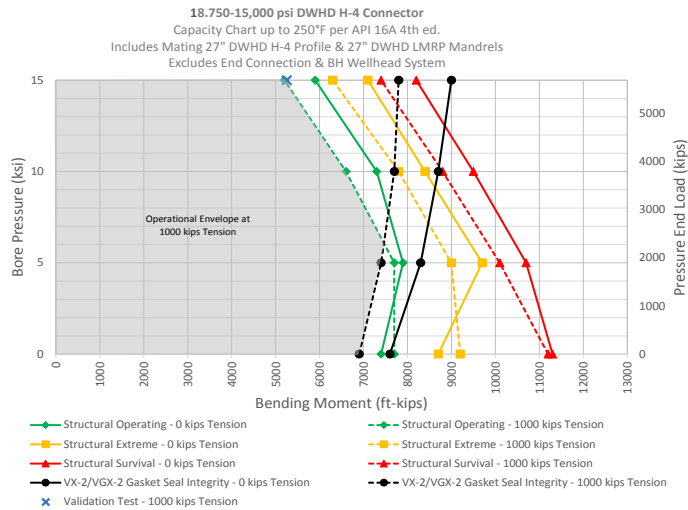

18-3/4" SHD H-4 connector

18-3/4" SHD H-4 connector shown below with 27" kit



18-3/4" 15ksi SHD H-4 load capacity envelope with 27" kit

Operational load capacity at 2/3 yield strength, extreme load capacity at 0.8 yield strength, survival load capacity at yield strength per API 16A

Note: Widow values at the wellhead for 3,000 psi connector locking pressure

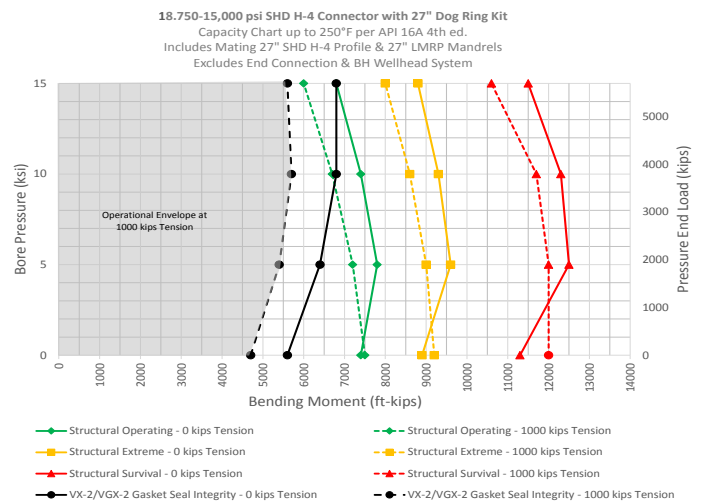

18-3/4" DWHD H-4 Technical Specifications

Based on connection with DWHC MS-700	Measurement
Hydraulic circuits	10
Lock fluid volume (US gal)	12.10
Unlock fluid volume (US gal)	15.10
Outside diameter (inches)	62
Weight (lbs)	25,770
Swallow (inches)	32.25
Max. service pressure (psi)	15,000
Max. hydraulic oper. pressure (psi)	3,000
API 16A conformance status	4th Edition PR1

18-3/4" SHD H-4 Technical Specifications

Based on connection with DMS-700	Measurement
Hydraulic circuits	10
Lock fluid volume (US gal)	12.10
Unlock fluid volume (US gal)	15.10
Outside diameter (inches)	66
Weight (lbs)	28,600
Swallow (inches)	32.25
Max. service pressure (psi)	15,000
Max. hydraulic oper. pressure (psi)	3,000
API 16A conformance status	4th Edition PR1

18-3/4" 15ksi ExF HAR H-4 connector

18-3/4" ExF High Angle Release (HAR) H-4 connector shown with studded top. The HAR connector is often located between the lower marine riser package and the lower stack

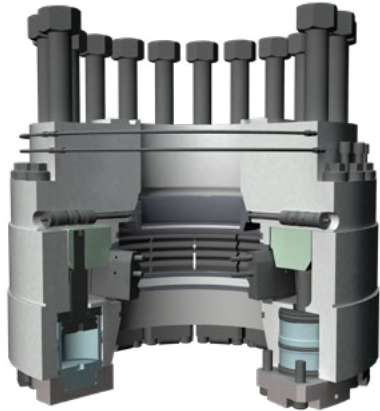

18-3/4" 10ksi E H-4 connector

18-3/4" E H-4 connector shown with hub connection

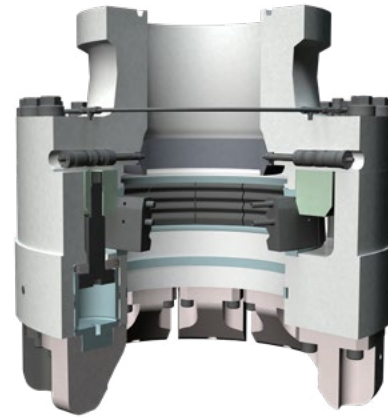

18-3/4" 15ksi ExF HAR H-4 load capacity envelope

Operational load capacity at 2/3 yield strength, extreme load capacity at 0.8 yield strength, survival load capacity at yield strength per API 16A

Note: Tension values at the wellhead for 3,000 psi connector locking pressure

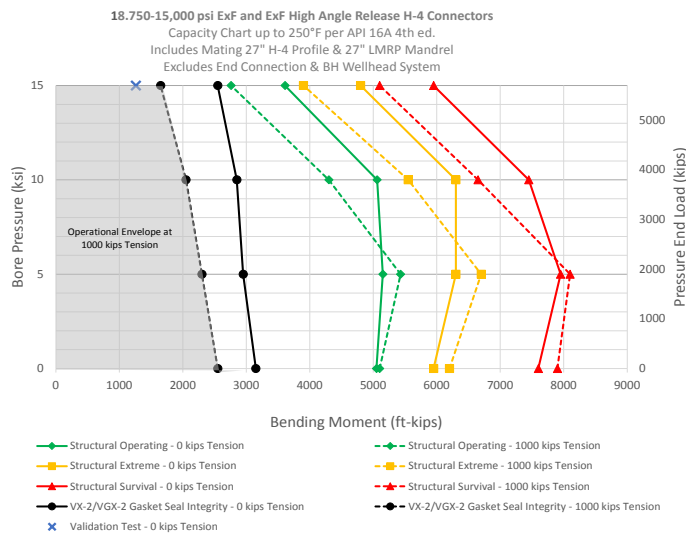

18-3/4" 10ksi E H-4 load capacity envelope

Operational load capacity at 2/3 yield strength, extreme load capacity at 0.8 yield strength, survival load capacity at yield strength per API 16A

Note: Tension values at the wellhead for 3,000 psi connector locking pressure

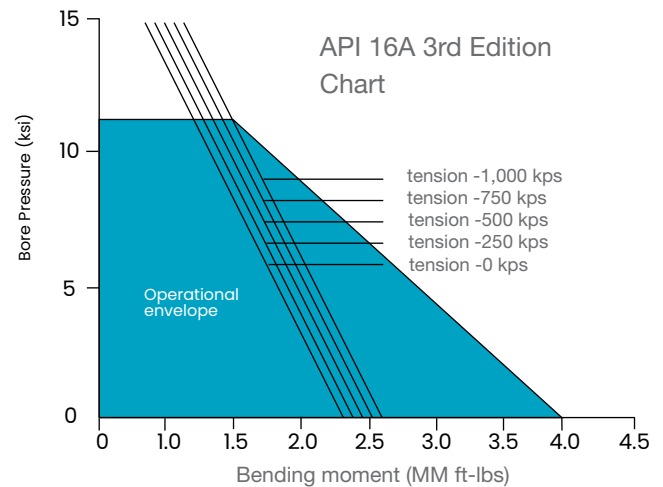

18-3/4" ExF HAR H-4 Technical Specifications

Based on connection with MS-700	Measurement
Hydraulic circuits	12
Lock fluid volume (US gal)	4.14
Unlock fluid volume (US gal)	5.16
Outside diameter (inches)	51.5
Weight (lbs)	14,200
Swallow (inches)	27.5
Max. service pressure (psi)	15,000
Max. hydraulic oper. pressure (psi)	3,000
API 16A conformance status	4th Edition PR1

18-3/4" E H-4 Technical Specifications

Based on connection with MS-700	Measurement
Hydraulic circuits	10
Lock fluid volume (US gal)	3.45
Unlock fluid volume (US gal)	4.30
Outside diameter (inches)	46.88
Weight (lbs)	10,500
Swallow (inches)	27.5
Max. service pressure (psi)	10,000
Max. hydraulic oper. pressure (psi)	3,000
API 16A conformance status	3rd Edition

16-3/4" 15ksi HD H-4 connector

16-3/4" HD H-4 connector shown with flanged top



16-3/4" 15ksi HD H-4 load capacity envelope with 25 3/4" kit

Operational load capacity at 2/3 yield strength, extreme load capacity at 0.8 yield strength, survival load capacity at yield strength per API 16A

Note: 1000 kip tension values at the wellhead for 3,000 psi connector locking pressure

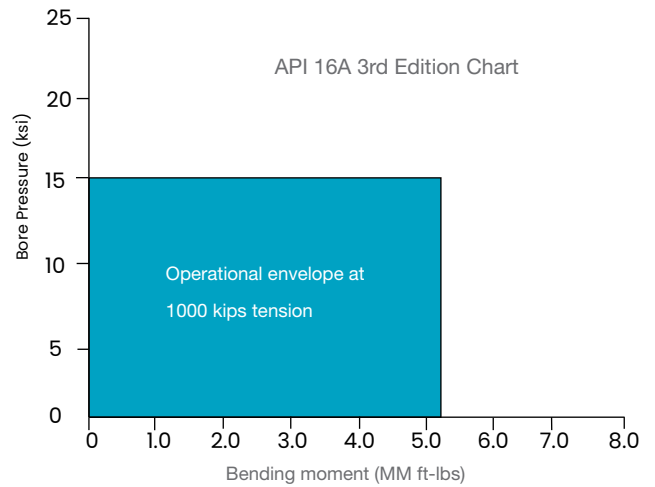

16-3/4" HD H-4 Technical Specifications	
Based on connection with 25-3/4" MS-700	Measurement
Hydraulic circuits	10
Lock fluid volume (US gal)	12.10
Unlock fluid volume (US gal)	15.10
Outside diameter (inches)	62
Weight (lbs)	25,953
Swallow (inches)	32.25
Max. service pressure (psi)	15,000
Max. hydraulic oper. pressure (psi)	3,000
API 16A conformance status	3rd Edition

Nomenclature

When there are two different letters, i.e. “CxD”, “CxE”, “ExF”

- First letter applies to the mandrel size
- Second letter denotes the hydraulic section (cylinders)

Nomenclature exceptions:

- H.A.R. (High Angle Release) is an ExF connector with modified swallow to allow release at higher rig offsets
- HD H-4 (Heavy Duty H-4)
- DWHD H-4 (Deep Water Heavy Duty H-4)
- SHD H-4 (Super Heavy Duty H-4)

H-4 Connector Style Options						
System Size	H-4 Style	Mandrel, Wellhead or Test Stump	Mandrel Size	Typical Wellhead Style	Gasket Type	Number of Pistons
13-5/8" - 5,000 psi	C	C	20-1/2	SG-1	AX	8
13-5/8" - 10,000 psi	CxD	C	20-1/2	SG-1	VX	8
13-5/8" - 15,000 psi	CxE	C	20-1/2	SG-1	VX	10
16-3/4" - 5,000 psi	D	D	25-3/4	SG-1	AX	8
16-3/4" - 10,000 psi	DxE	D	25-3/4	MS-700, SG-5	VX	10
16-3/4" - 15,000 psi	HD	D	25-3/4	MS-700	VX	10
18-3/4" - 10,000 psi	E	E	27	MS-700, SG-5	VX-2	10
18-3/4" - 10,000 psi or 15,000 psi	ExF	E	27	MS-700, SG-5	VX-2	12
18-3/4" - 10,000 psi or 15,000 psi	DWHD	DWHD	27	DWHC MS-700, DWHC MS-800, MS-700SFX, MS-800SFX	VX-2	10
18-3/4" - 15,000 psi	SHD	DWHD	27	DWHC MS-700, DWHC MS-800, MS-700SFX, MS-800SFX	VX-2	10
18-3/4" - 20,000 psi	SHD	Super	30	SMS-800	VGX-2	10
18-3/4" - 15,000 psi	SHD	Super	30	SMS-800	VX-2	10