

MH PTD-500-AC-1250

Portable Top Drive

HMH's high-performance MH PTD-500-AC-1250 combines outstanding torque, power and speed with the most compact and light weight design in its performance class. It meets all drilling requirements for 1500 hp land rigs with 320 short tons up to 2000 hp land rigs with high capacity of 500 short tons

Product description

HMH's portable top drive MH PTD-500-AC-1250 incorporates more than 35 years of field experience in harsh environments and is based on recognized industry standards and regulations.

Our portable top drive is equipped with a 1250 hp AC drilling motor and a gearbox with helical gears, providing maximum torque and speed. The precisely welded equipment design, as well as the included premium gears, deliver a highly robust solution safeguarding the equipment's integrity and longevity.

Rig up and down time is significantly reduced by quick connectors on all cables in the service loop. They allow to connect and disconnect the cables within minutes. Additionally, this work can be performed by the regular drill crew, without the need of special electrical personnel. Further quick disconnectors within the hydraulics, also speed-up handling.

With its compact envelope and a flexible torque tube design, the MH PTD-500-AC-1250 is compatible with all mast and derrick designs. The service loop with integrated loop saddle provides even more flexibility.

Benefits

- Outstanding torque and speed in its class
- Minimized rig up/down time
- Most compact and light weight design in its class
- Compatible with all mast and derrick designs
- Up to 70 % improved rate of penetration with optional SoftTorque Z technology
- Highly flexible pipe handling

The MH PTD-500-AC-1250 is also highly flexible when it comes to pipe handling: the increased link tilt capacity and tilt angle allows the use of heavy elevators and enables drilling closer to the drill floor.

Integration of the optional SoftTorque Z technology can further increase your drilling performance by mitigating oscillations on the drill bit and torsional vibrations and therefore reducing the stick-slip effect.

Key features

- Condition Based Maintenance (CBM)
- CE marking
- Various elevator links, saver subs, wire-line guide, travelling block adaptors, etc.
- High torque wrench
- SoftTorque Z technology



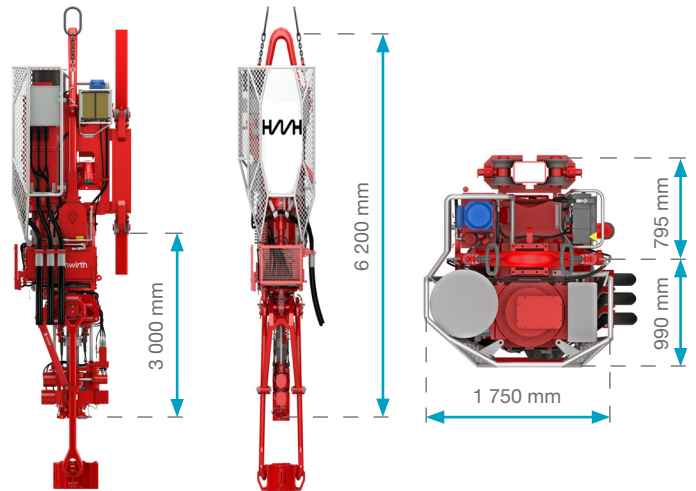
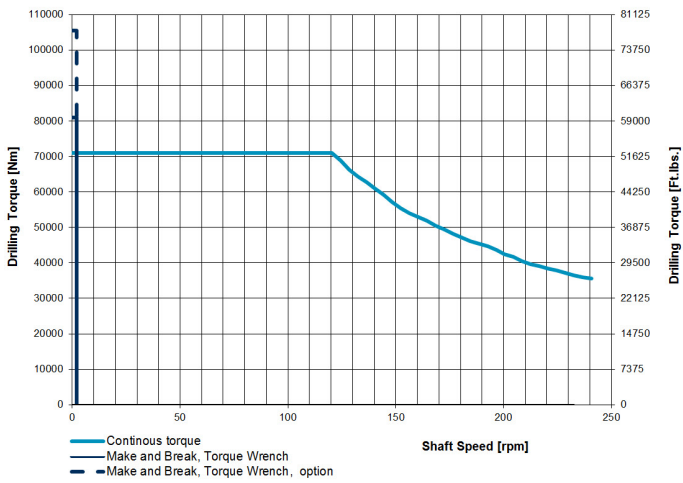

Technical Specifications

Top drive weight, including dolly	33 510 lb (15 200 kg)
Motor type	AC induction motor, air cooled
Power rating	1 250 hp (945 kW)
Height	20.3 ft (6.2 m)
Drilling torque, max continuous	52 360 lbf-ft (71 000 Nm)
Speed @ max. continuous drilling torque	120 rpm
Speed, max.	240 rpm
Load rating	500 short tons (453.6 mT)
Pressure rating	7 500 psi (517 bar)
IBOP pressure rating	15 000 psi (1 034 bar)
Water course (main shaft inner diameter)	3 in (76 mm)
Torque wrench make/break capacity	60 000 lbf-ft (81 000 Nm)*
Ambient temperature, min./max.	-4/+131°F (-20/+55°C)

* Optional high torque wrench with 78 000 lbf-ft (105 500 Nm) capacity
Data is subject to confirmation by the manufacturer.